

PU086T P-DRIVE

◎ POWER RATING

Intermittent rating kW(PS) / rpm	Max. torque N.m(kg.m) / rpm	Fuel consumption g/kW.h(g/PS.h) / rpm
151 (205) / 2,200	793 (80.8) / 1,400	216 (159) / 2,200

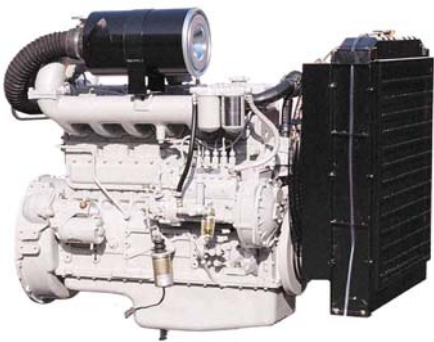

Note : -. The engine performance corresponds to ISO 3046.

◎ MECHANICAL SYSTEM

- Engine Model PU086T
- Engine Type In-line 4 cycle, water cooled
 Turbo charged
- Combustion type Direct injection
- Cylinder Type Replaceable dry liner
- Number of cylinders 6
- Bore x stroke 111(4.37) x 139(5.47) mm(in.)
- Displacement 8.071(492.49) lit.(in3)
- Compression ratio 16.8 : 1
- Firing order 1-5-3-6-2-4
- Injection timing 12° BTDC
- Compression pressure Above 28 kg/cm²(398 psi) at 200rpm
- Dry weight Approx. 780 kg (1,720 lb)
- Dimension 1,277 x 824 x 1,001 mm
 (LxWxH) (50.3 x 32.4 x 39.4 in.)
- Rotation Counter clockwise viewed
 from Flywheel

◎ MECHANISM

- Type Over head valve
- Number of valve Intake 1, exhaust 1 per cylinder
- Valve lashes at cold Intake 0.30 mm(0.0118 in)
 Exhaust 0.30 mm(0.0118 in.)

◎ VALVE TIMING

	Opening	Close
○ Intake valve	16 deg. BTDC	36 deg. ABDC
○ Exhaust valve	46 deg. BBDC	14 deg. ATDC

◎ OPTION & ACCESSORY PARTS

- Engine parts Fly wheel & housing
 Intake & exhaust manifold
- Accessory parts Raditor, silencer & air cleaner
- Electrical parts Gauge panel & stop solenoid

◎ FUEL SYSTEM

- Injection pump Zexel in-line "AD" type
- Governor RSV type(all speed control)
- Feed pump Mechanical type
- Injection nozzle Multi hole type
- Opening pressure 214 kg/cm² (3,044 psi)
- Fuel filter Full flow, cartridge type
- Used fuel Diesel fuel oil

◎ LUBRICATION SYSTEM

- Lub. Method Fully forced pressure feed type
- Oil pump Gear type driven by crankshaft
- Oil filter Full flow, cartridge type
- Oil pan capacity High level 15 liters (4.09 gal.)
 Low level 12 liters (3.17 gal.)
- Angularity limit Front down 25 deg.
 Front up 25 deg.
 Side to side 25 deg.
- Lub. Oil Refer to Operation Manual

◎ PERFORMANCE CURVE

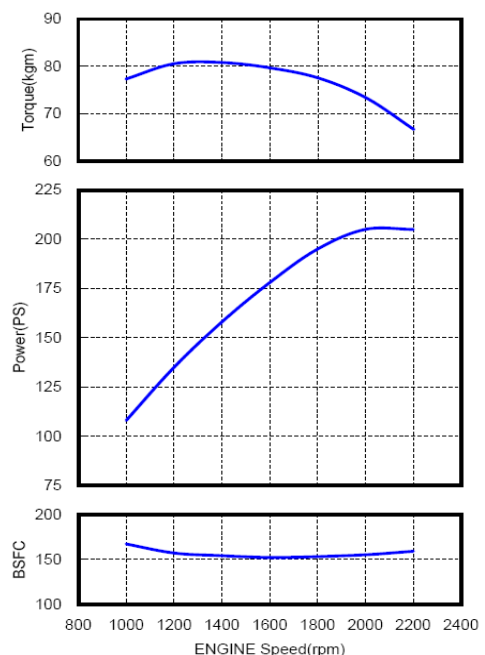

◎ COOLING SYSTEM

- Cooling method Fresh water forced circulation
- Water capacity 14 liters (3.70 gal.)
(engine only)
- Pressure system Max. 0.9 kg/cm² (12.8 psi)
- Water pump Centrifugal type driven by belt
- Water pump Capacity 190 liters (41.8 gal.)/min
at 2,200 rpm (engine)
- Thermostat Wax – pellet type
Opening temp. 71°C
Full open temp. 85°C
- Cooling fan Blower type, steel
590 mm diameter, 6 blade

◎ ELECTRICAL SYSTEM

- Charging generator 24V x 45A [or 12V x 26A] alternator
- Voltage regulator Built-in type IC regulator
- Starting motor 24V x 4.5kW [or 12V x 2.5kW]
- Battery Voltage 24V [or 12V]
- Battery Capacity 100 AH [or 150 AH](recommended)
- Starting aid (Option) Block heater

◎ ENGINEERING DATA

- Water flow 190 liters/min @2,200 rpm
- Heat rejection to coolant 21.0 kcal/sec @2,200 rpm
- Air flow 15.3 m³/min @2,200 rpm
- Exhaust gas flow 18.0 m³/min @2,200 rpm
- Exhaust gas temp. 530 °C @2,200 rpm
- Max. permissible restrictions
 - Intake system 220 mmH₂O initial
635 mmH₂O final
 - Exhaust system 1,000 mmH₂O max.

◆ CONVERSION TABLE

- in. = mm x 0.0394 lb/ft = N.m x 0.737
- PS = kW x 1.3596 U.S. gal = lit. x 0.264
- psi = kg/cm² x 14.223 kW = 0.2388 kcal/s
- in³ = lit. x 61.02 lb/PS.h = g/kW.h x 0.00162
- hp = PS x 0.98635 cfm = m³/min x 35.336
- lb = kg x 2.20462

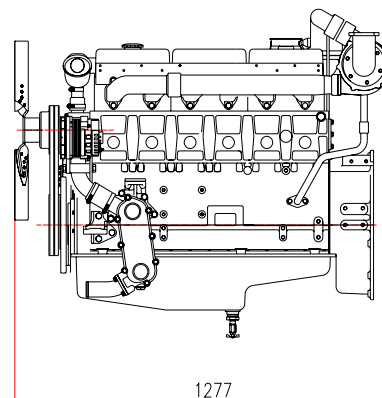
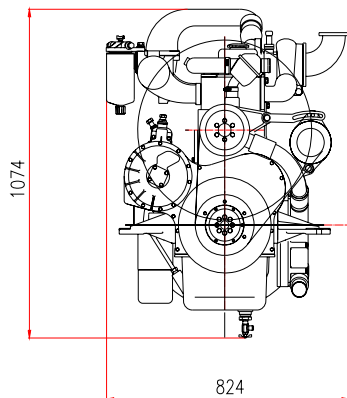

Head office

Westen of 6thFl,3Bldg,Allay1128,Jindu Rd,Minhang District ,Shanghai
TEL : 86-21-5680-0810, FAX : 86-21-5680-9005
 Shanghai Client Diesel Engine Co.,Ltd
Email : scdc@mtu-china.com
Web site : www.client-engine.com, www.mtu-china.com

※ Specifications are subject to change without prior notice